

# *Rogue EM 190 PRO*

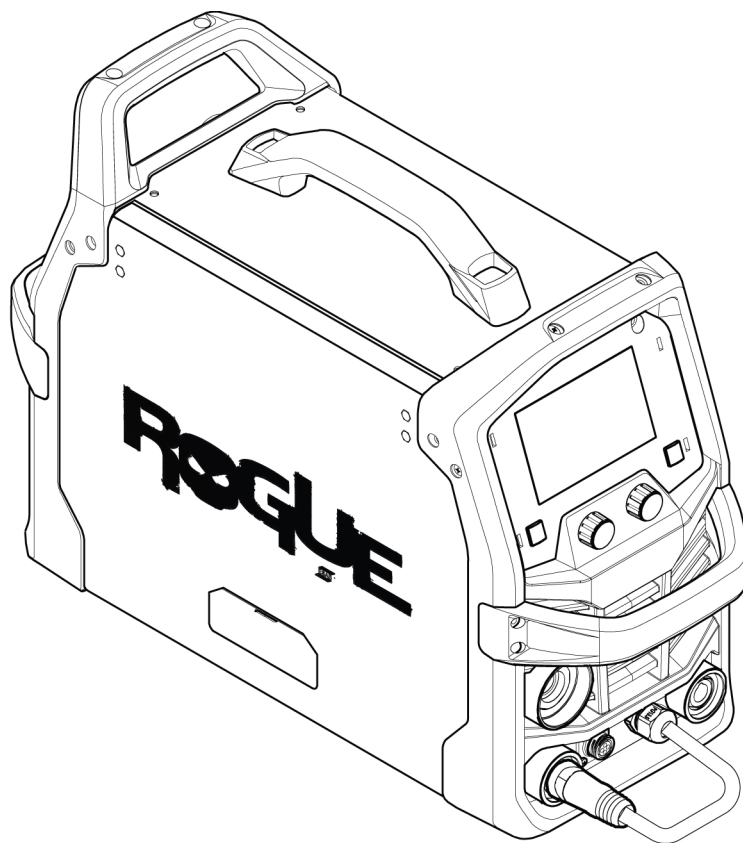

## **Spare parts list**

<b>Ordering no.</b>	<b>Denomination</b>	<b>Notes</b>
0700 301 083	Rogue EM 190 PRO	Welding power source
0447 956 *	Rogue EM 190 PRO	Instruction manual

Spare parts may be ordered through your nearest ESAB dealer, see [esab.com](http://esab.com). When ordering, please state product type, serial number, denominations and ordering numbers according to the spare parts list. This facilitates dispatch and ensures correct delivery.

Maintenance and repair work should be performed by an experienced person, and electrical work only by a trained electrician. Use only recommended spare parts.

For accessories to the product, see the instruction manual.

The three last digits in the document number of the manual show the version of the manual. Therefore they are replaced with \* here. Make sure to use a manual with a serial number or software version that corresponds with the product, see the front page of the manual.

TABLE OF CONTENTS

---

- 1 SPARE PARTS ..... 4**
- 1.1 Housing module ..... 4**
- 1.2 Connection parts ..... 6**
- 1.3 User interface ..... 8**
- 1.4 Spool hub assembly ..... 9**

# 1 SPARE PARTS

## 1.1 Housing module

C = Component designation in the circuit diagram					
Item	Qty	Ordering no.	Denomination	Notes	C
1	1	0558 102 972	Door panel	Rogue (no label)	
2	2		Connecting bracket	Front-rear	
3	1		Connecting bracket	Lifting handle	
4	1	0558 111 142	Rear panel	EM/EMP/ET	
5	2	0558 111 143	Front/rear handle	EM/EMP	
6	8	0558 102 968	Screw	Pan head, M4×12, T-20, black	
7	1	0558 102 983	Cover	Rogue EM/EMP (no label)	
8	20		Screw	Pan head, M5×25, T-25, black	
9	1	0464 670 007	Handle	Without covers	
10	6		Screw	Pan head, M5×25, T-25, black	
11	2	0558 102 999	Screw cover	Blind hole	
12	1	0558 102 947	Base	Rogue EM/EMP (no label)	
13	1		Center baffle	Rogue EM/EMP	
14	1	0558 111 140	Front panel	EM/EMP	
15	1	0558 111 154	Mains mount panel	EM/EMP/ET	
16	2		Center baffle bracket	Rogue EM/EMP	
17	2	0558 111 148	Access panel cover	Front/rear, EM/EMP/ET	
18	2	0558 111 144	Top handle cover	EM/EMP/ET	
19	17		Screw	Pan head, M4×8, T-20, black	
20	2	0558 111 151	Door hinge	EM/EMP	
21	2	0558 102 969	Screw	Counter sunk, M4×8, philips, black	
22	1	0558 111 149	IP louver panel	EM/EMP	
23	1		Weld output cover		
24	1		Bulkhead access cover		
25	1	0558 111 152	Door latch	EM/EMP	
26	1	0558 111 115	Side label	Rogue	
27	1	0558 111 101	Door chart par. label		
28	1	0558 111 114	Side label	ESAB	
29	1		Rating label		
30	1	0558 111 096	General precautionary label	CSA	
31	1		Lower rear gas label		

1 SPARE PARTS

C = Component designation in the circuit diagram					
Item	Qty	Ordering no.	Denomination	Notes	C
32	1		Upper rear mains label	120 V / 230 V	
33	1		Lower front remote-polarity label		

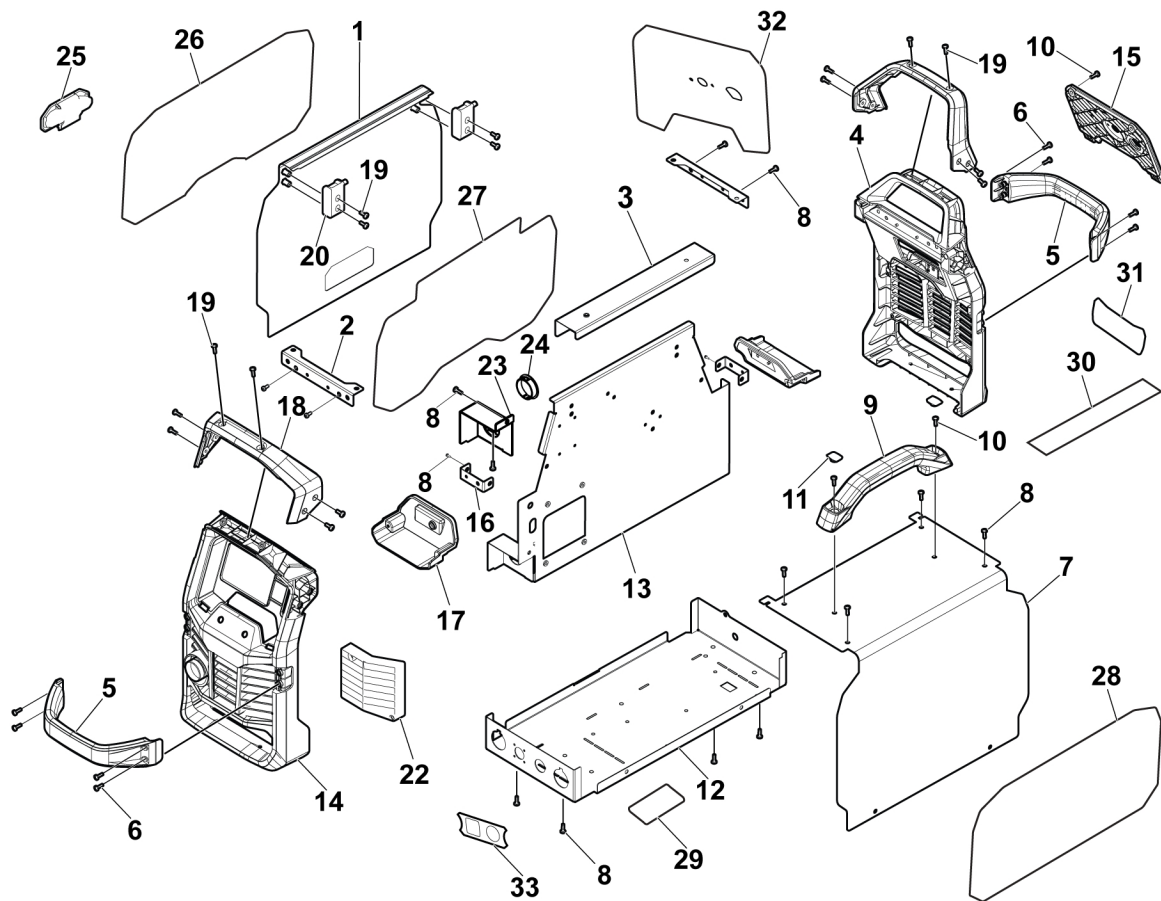

## 1.2 Connection parts

<b>C = Component designation in the circuit diagram</b>					
<b>Item</b>	<b>Qty</b>	<b>Ordering no.</b>	<b>Denomination</b>	<b>Notes</b>	<b>C</b>
1	1	0464 674 013	Rotary switch	1T/1P, 20 A / 690 V	2QF1
2	1	0558 102 956	Mains cable	3×2.5 mm <sup>2</sup> ×3.8 m, SOOW, 250 V, 16 A plug	
3	1		Fan shroud		
4	2		Insulator	Primary/secondary	
5	1	0558 102 951	Main control inverter PCBA		15AP1
6	1	0558 102 949	PFC PCBA		17AP1
7	1		Power block mounting support		
8	1		Insulating mounting support		
9	1		PFC inductor		
10	1	0558 102 952	Rectifier PCBA		20AP1
11	2	0558 102 978	Female OKC connector	With insulator, 50 mm <sup>2</sup>	
12	1	0558 102 976	Strain cable relief connector	EG-13.5	
13	1	0558 102 975	Receptacle with harness	Trigger, 8-pin	
14	1	0464 674 002	Cable strain relief connector	EG-16	
15	1		Female/male tracheal joint fitting	90°	
16		0558 102 989	Nut	Brass, M14×1.5	
17	1	0558 102 971	Fan with leads		FM
18	1	0558 102 959	Ribbon cable	8P×150 mm, connection: 15AP1 to wire feed control PCB	
19	4		Screw	Pan head, M3×8, T-10, black	
20	4		Hex nut	M3	
21	1	0558 102 958	Gas valve lead set		
22	1	0558 102 963	Negative weld cable	5 AW-G/16 mm <sup>2</sup> , 190 mm	
23	1	0558 102 955	Positive weld cable	5 AW-G/16 mm <sup>2</sup> , 28	
24	1	0558 102 973	Filter remote PCBA		21AP1
25	1	0558 102 977	Gas valve	24 V DC, 0.8 MPa (116psi)	GV1
26	2	0558 102 979	Female/male tracheal joint fitting		
27	1	0558 102 950	Wire feed control PCBA		
28	1		Air baffle		
29	1	0558 102 966	Main PCBA insulator		

1 SPARE PARTS

C = Component designation in the circuit diagram					
Item	Qty	Ordering no.	Denomination	Notes	C
30	1	0558 102 965	EMC insulator		
31	1		Busbar grounding		
32	1	0558 102 957	Polarity reversing cable	male, 50 mm <sup>2</sup>	
33	1	0558 102 954	Primary interconnect PCBA		2AP2
34	1	0558 102 990	Female gas fitting	5/8"-18 RH	
35	2	0558 102 960	Ribbon cable	5P×300 mm, connection: 1AP2 to 21AP1	

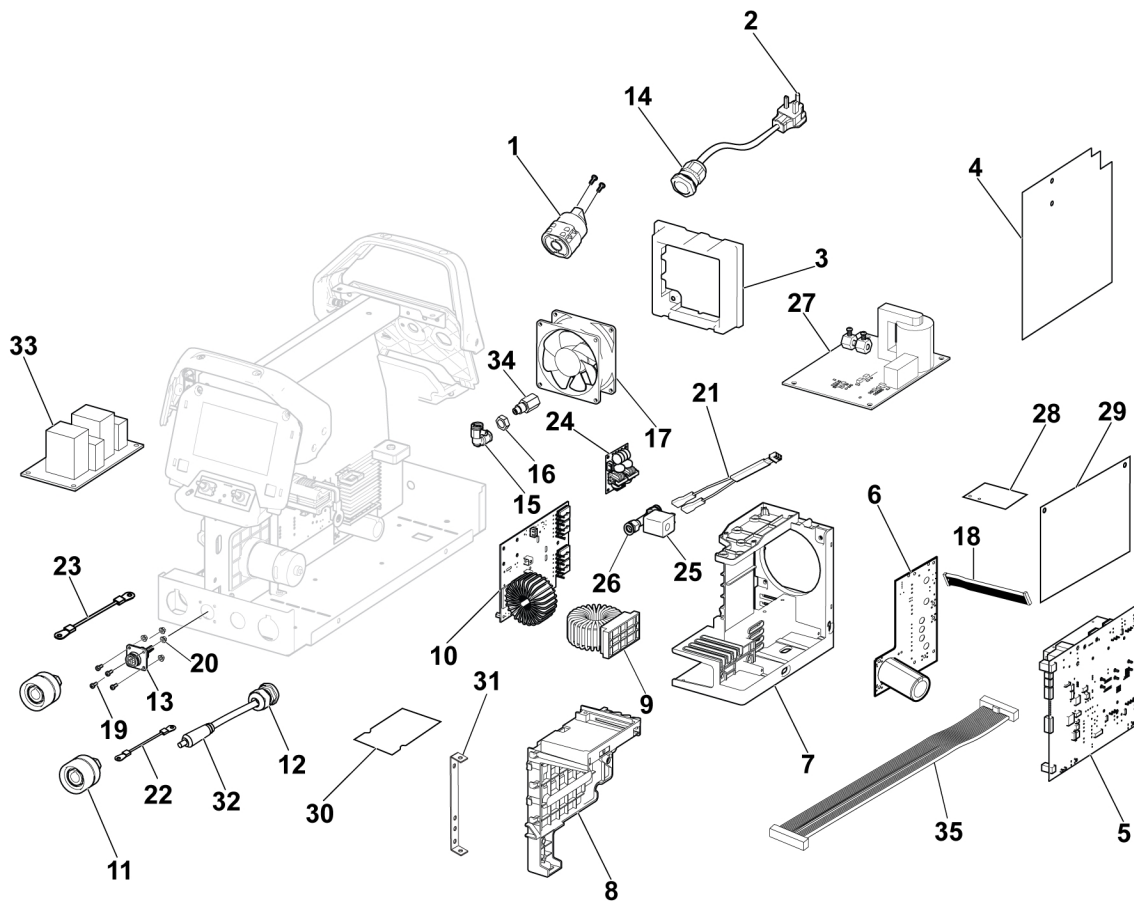

### 1.3 User interface

C = Component designation in the circuit diagram					
Item	Qty	Ordering no.	Denomination	Notes	C
1	1	0558 102 948	TFT control panel PCBA		1AP1
2	1	0558 111 156	UI mount panel	EM/EMP PRO	
3	2	0464 672 003	Push button cover	Rubber	
4	1	0464 672 004	Control knob		
5	1	0558 102 953	Encoder control PCBA		1AP2
6	2		Screw	Pan head, M5×25, T-25, black	
7	1	0558 102 991	Ribbon cable	5P×150 mm, connection: 1AP2 to 1AP1	
8	1	0558 102 962	Ribbon cable	8P×100 mm, connection: 1AP2 to 1AP1	
9	1	0558 111 132	User interface label		
10	1		Front encoder label		
11	1		Label	Rogue EMP 190	
12	1	0558 102 961	Ribbon cable	5P×250 mm, connection: 1AP2 to 21AP1	

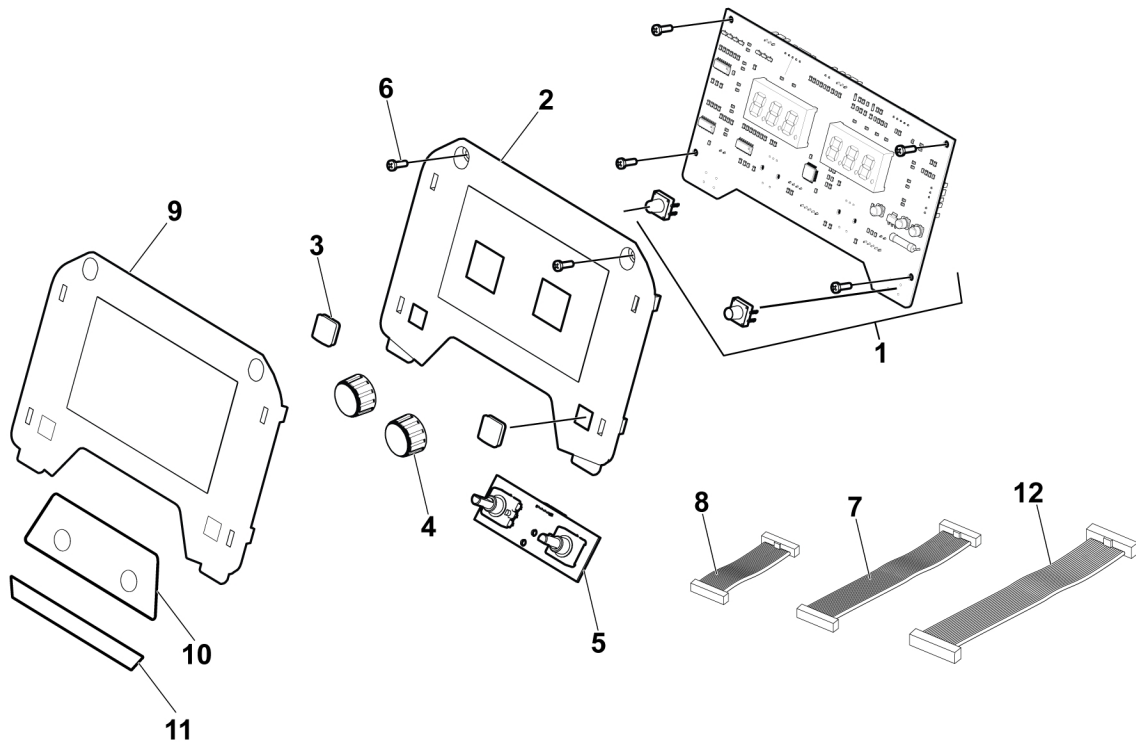



## 1.4 Spool hub assembly

C = Component designation in the circuit diagram					
Item	Qty	Ordering no.	Denomination	Notes	C
1	1	0558 103 001	Spool hub assembly		
2	1	0558 102 981	Wire drive gear box	With motor and drive	M1
3	1	0558 111 147	Drive stand support	EM/EMP	
4	2		Screw	Pan head, M6×20, #2 Phillips, black	
5	2		Locking nut	M6	AP
6	4		Screw	Pan head, M5×12, T25, black	
7	1	0558 102 994	Inch/purge momentary rocker switch	2P/2T with leads	13XS1
8	1	0558 102 964	Wire drive harness		
9	1	0558 102 982	Torch receptacle	Tweco	
10	1	0558 102 967	Torch retention knob	M5×12	
11	1		Jog/purge caution label		

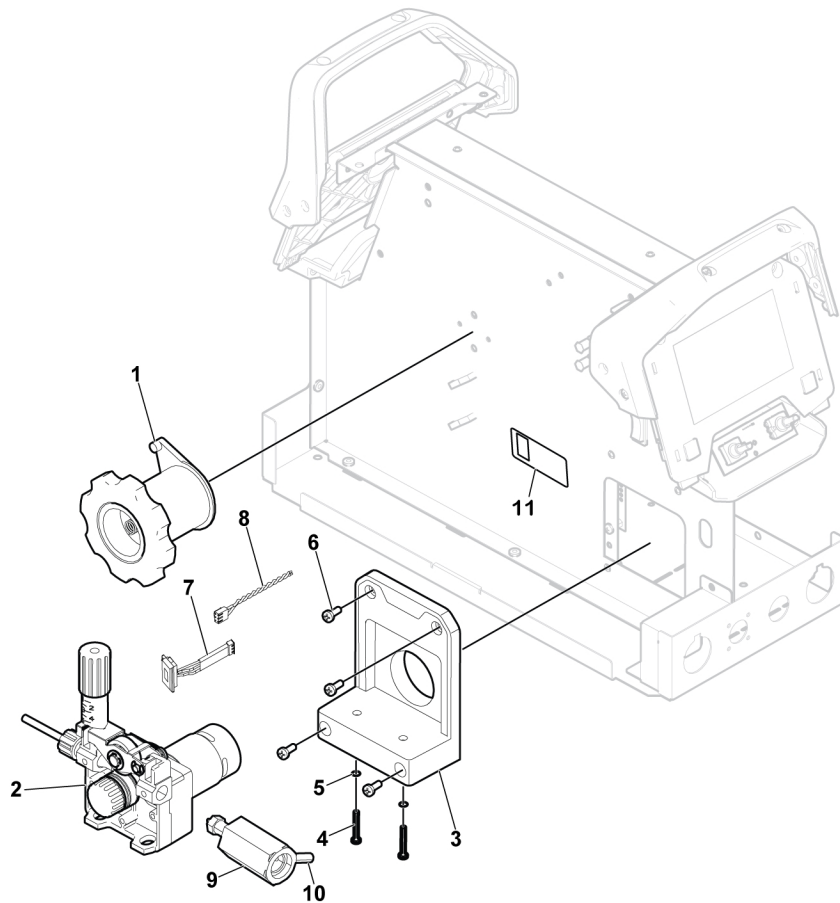



# A WORLD OF PRODUCTS AND SOLUTIONS.



For contact information visit <http://esab.com>

ESAB AB, Lindholmsallén 9, Box 8004, 402 77 Gothenburg, Sweden, Phone +46 (0) 31 50 90 00

[manuals.esab.com](http://manuals.esab.com)

